

# Methane into markets utilizing animal waste in Bali Province, Indonesia

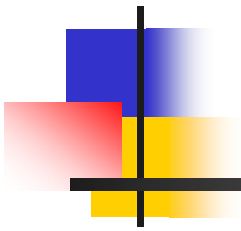

I Nyoman Suprpta Winaya\*

AAG Alit Sastrawan

Udayana University, Bali-Indonesia

**East Asian Seas Congress**

**Manila, November 24, 2009**



# Outline

---

- Potential of biogas technology
- Bali and its resources
- Waste management method
- Methane recovery opportunity
- Biogas production in Bali
- Prospect for market



# Current Condition

---

- The price of fossil energy is volatile
- High energy consumption in Indonesia
  - Electricity ratio is 63.9%
  - Growth of electricity demand is 7.1%
- Agriculture dominant country with various available livestock
- High land availability
- New and renewal sources as alternative energy
- Biogas technology allows participants; e.g. farmer



# Potential of using Biogas Technology

---

Animal manure: methane recovery

*Manure management  
methods:*

Solid fertilizer , compost,  
Liquid effluent, open lagoon

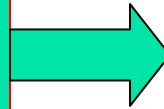

*Methane recovery method:*

Manure treatment system:

- Anaerobic treatment with methane recovery/utilization
- Aerobic treatment

Capturing methane and using it to be a useful energy for cooking and electricity utility

# Biogas digester of animal wastes

*The biogas digester of animal wastes creates methane*

*The remaining solids can be used for:*

- **Fertilizer**
- **Animal bedding (sterilized of all pathogens)**
- **Gasification**

*Recycled Water can be used for farming*

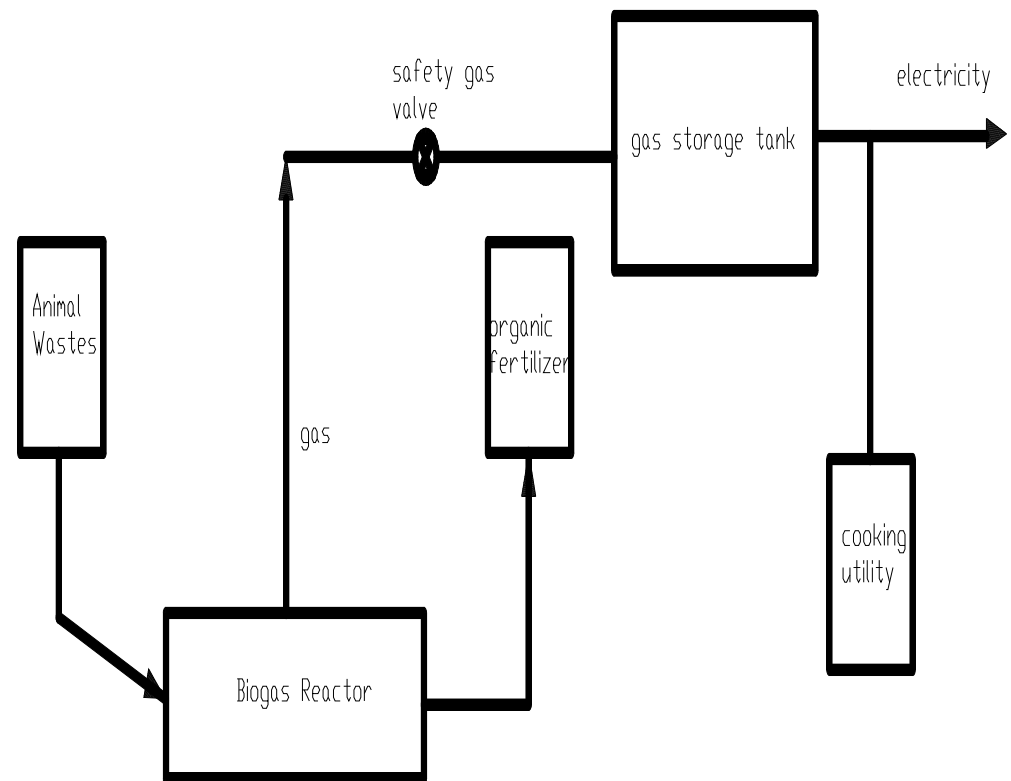



# History of Biogas

---

- 16th century - Used to heat water in Persia
- 17th century - Flammable gases found to be emitted from decaying organic matter
- 1808 - Methane produced via controlled anaerobic digestion of cattle manure
- 1859 - First digestion plant built in Bombay
- 1970s - Energy crisis renewed interest in anaerobic digestion
- 1980s - First digestion plant was first introduced in Indonesia
- 1990s - Some small digestion plant in operation in Indonesia
- Estimated more than 500 digester are currently in operation in Bali



# What is Anaerobic Digestion?

---

High rich combustible gas  
by anaerobic microbes  
to Biogas and Manure Effluent



Methane ~ 60%  
Carbon Dioxide ~ 40%  
Hydrogen sulfide ~ trace

# Anaerobic Digestion Process

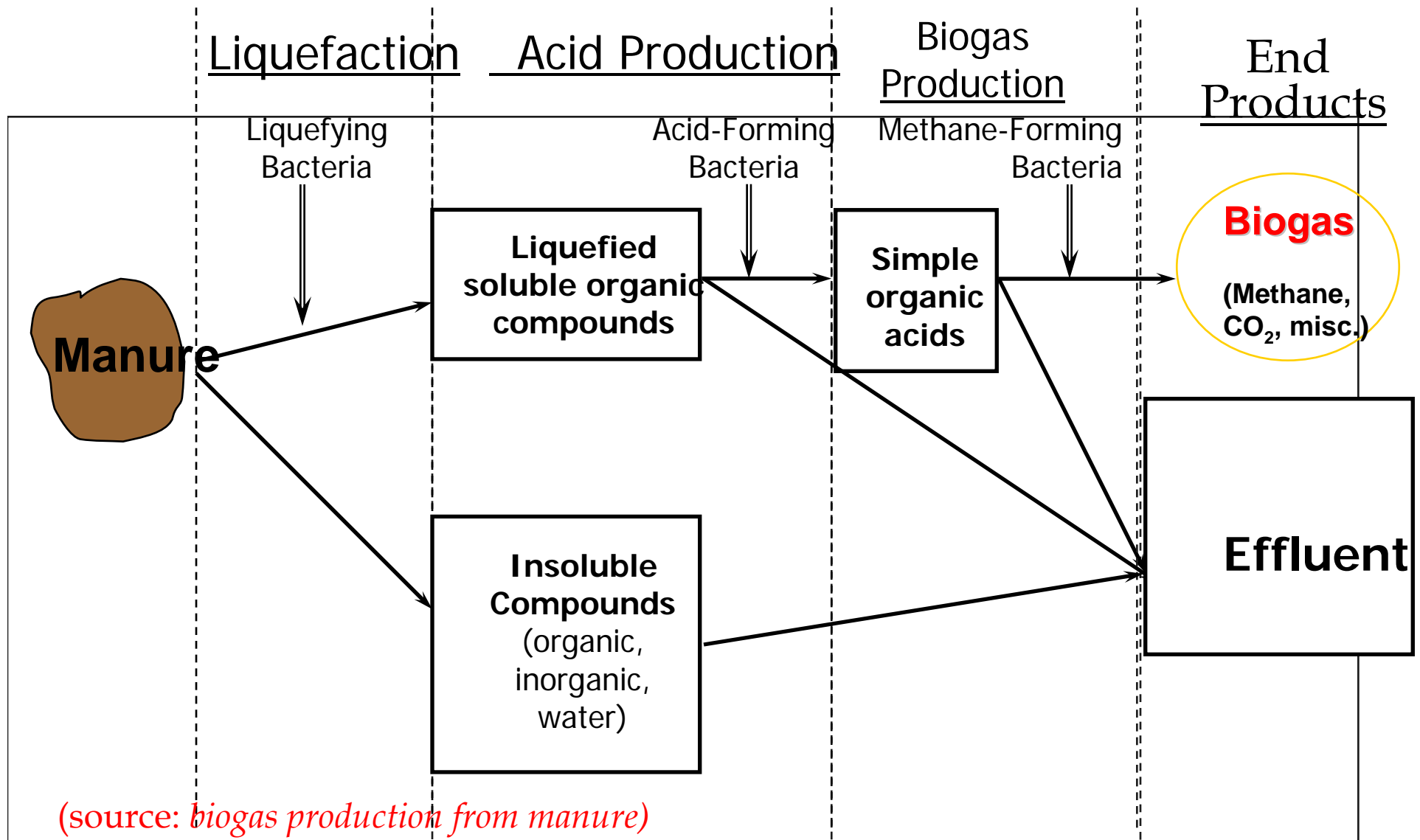

# More Details on the Digestion Process

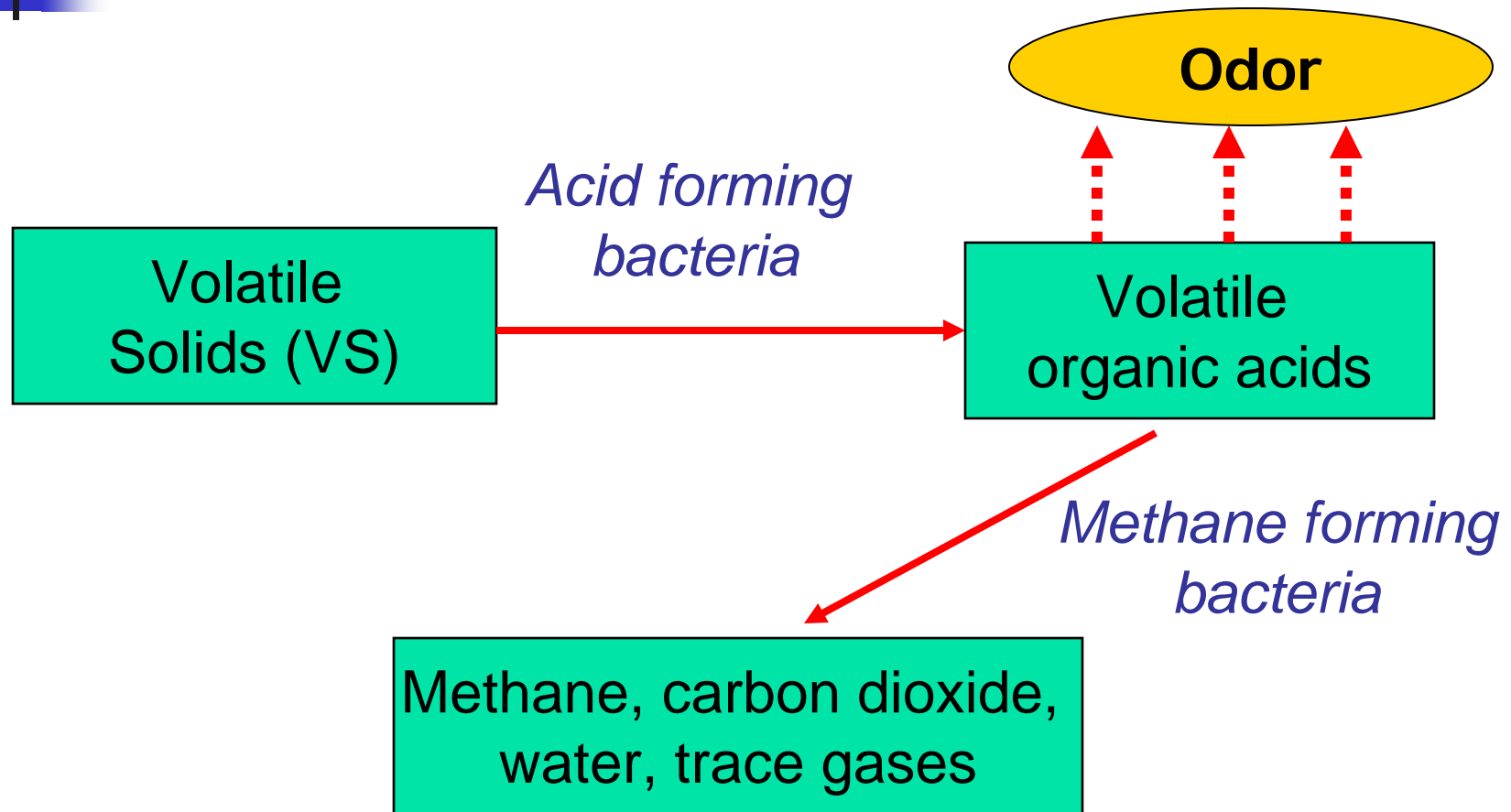



# Environmental Benefits of Biogas Systems

---

- Odor reduction (digestion stabilizes degradable organic matter)
- Digested manure retains most of its nutrient/fertilizer value
- Reduce surface and groundwater contamination.
- Destroy pathogens and weed seeds.
- Reduce atmospheric emissions of methane, a powerful greenhouse gas (methane is over 20 times more damaging than carbon dioxide)
- Provide on-farm energy.
- Create jobs related to the design, operation, and manufacture of energy recovery systems

# Bali and its resources



- Agriculture sector is 21.37%

- Tourism sector is 63.26

- Industry sector is 15.37%



The best tourism destination in the world

- Agriculture dominated country

- In Bali, mostly farmer with small land having 2-5 head livestock

- Number of livestock: 2.0 million head

# Bali cattle

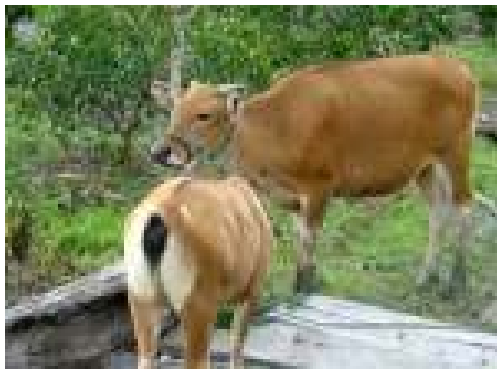

- Bali cattle breed is one of the few existing cattle indigenous breeds in Indonesia
- able to survive on poor pasture land and their lean
- simply tethered near the home or put out to pasture on communal grazing land

It is difficult to handle animal wastes wisely in order to minimize environmental problems



# Biogas production in Bali

- Oil-drum demonstration units (digesters made of one or more empty oil drums) include a train of six double-drum poultry manure units at Denpasar in 1980s.
- It is planned to construct biogas for 3000 units under *Debt Nature for Swap* (DNS) program
- Recently, about 500 polyethylene-plastic tubes were built

<i>Regency</i>	<i>Number of plant</i>	<i>User</i>
Tabanan	23	Farmer
Bangli	15	Farmer
Buleleng	5	Farmer
Jembrana	10	Farmer
Denpasar	12	Farmer
Badung	3	Farmer
Gianyar	3	Farmer

Source:  
Mulya Tiara Nusa

# Family-size Biogas design

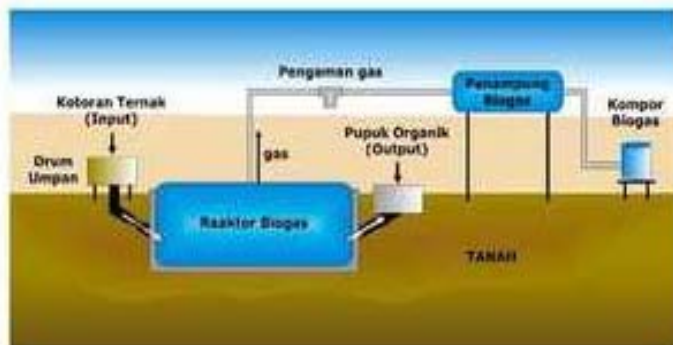
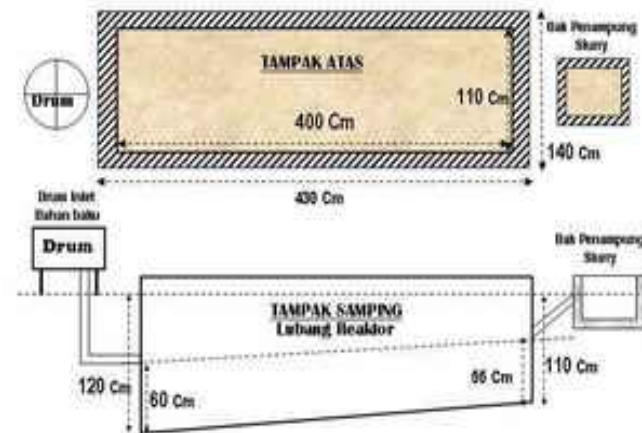

# Family-size Biogas design



Source: Mulya Tiara Nusa

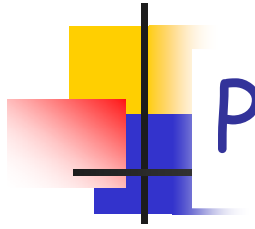

## Prospect for market

- Thousand numbers of family-sized, low technology digesters provide biogas for cooking and lighting
- There is a possibility for biogas production on the big farms
- There is a possibility to use biogas plant at massive use in the village



# Problems identified

---

- The average lifetime of a plastic tube digester only around 2-3 years
- Require a financial investment which is an important obstacle in biogas development
- Lack of efficient system of financial incentive instruments aimed at massive use of renewable energy sources
- The government policies on biogas must not only quantity but also quality
- Require continuous promotion monitoring, routine maintenance and repair that should not be underestimated



# Conclusion

---

- Biogas technology is efficient and profitable waste management system
- The possibility for the farmers linked to methane capture and utilization activities of having additional revenues provides the opportunity to reinvest in production units to improve environment quality
- The public opinion of biogas technology from animal wastes is found generally positive